

Modular Heat Pump 460V



Job Name: _____ Date: _____

System Reference No.: _____ Engineer Signature: _____

Model: GMV-72WM/B-U(U)



Specifications	Unit	Parameter
Performance		GMV-72WM/B-U(U)
Rated Cooling Capacity(*1)	kBtu/h	72
Rated Heating Capacity(*2)	kBtu/h	81
Power Input	Cooling(kw)	5.45
	Heating(kw)	5.8
Sound Pressure Level	dB(A)	60
Operating Temperature Range	Cooling(Outdoor) °C/°F	-5~52 / 23~125.6
	Heating(Outdoor) °C/°F	-20~24 / -4~75.2
AHRI Ratings (Ducted/Non-Ducted)		
EER		11.1 / 11.3
SEER		20 / 23
COP		2.4~3.4 / 2.45~3.7
Electrical Data		
Power supply	Voltage, Phase, Hertz	460/3/60
Maximum Overcurrent Protection (MOP)	A	20
Minimum Circuit Amps (MCA)	A	15
Fan		
Type x Quantity		Axial-flow x 1
Air Flow Volume	CFM	6710
Fan Motor Running Current	A	1.4
Fan Motor Power Output	W	750
Max. External Static Pressure	In. W.G	0.33
Compressor		
Compressor Type x Quantity		Inverter Scroll x 1
Compressor Rated Load Amps (RLA)	A	10.1
Compressor Refrigerant Oil type		FVC68D or FV68H
Compressor Refrigerant Oil Charge Volume	L/Gal	4.6 / 1.22
Refrigerant Piping		
Connection Pipe	Gas (mm/inch)	3/4
	Liquid (mm/inch)	3/8
Max. Equivalent Connection Pipe Length (OD to ID)	ft	541
Refrigerant Charge	lbs	14.33
Refrigerant		R410A
Dimension/Weight		
Dimensions (HxWxD)	inch	63-3/16 x 36-5/8 x 30-1/8
Net Weight	lbs	503
Other		
Indoor Unit	Total Capacity(%)	50%-135% of outdoor unit
	Max Connectable Quantity	13
Safety Certification		ETL / AHRI / ENERGY STAR
Condenser Fin Color		Gold
Protection Devices	High Pressure	High pressure sensor, High pressure switch 601 psi (4.15 MPa)
	Inverter Circuit	Over-heat protection, Over-current protection
	Compressor	Discharge temp protection, Over-current protection

*1 Cooling | Indoor: 80°F(26.7°C)DB / 67°F(19°C)WB; Outdoor: 95°F(35°C)DB
 *2 Heating | Indoor: 70°F(21.1°C)DB / Outdoor: 47°F(8.3°C)DB / 43°F(6°C)WB

Outline and Physical Dimensions of GMV-72WM/B-U(U).

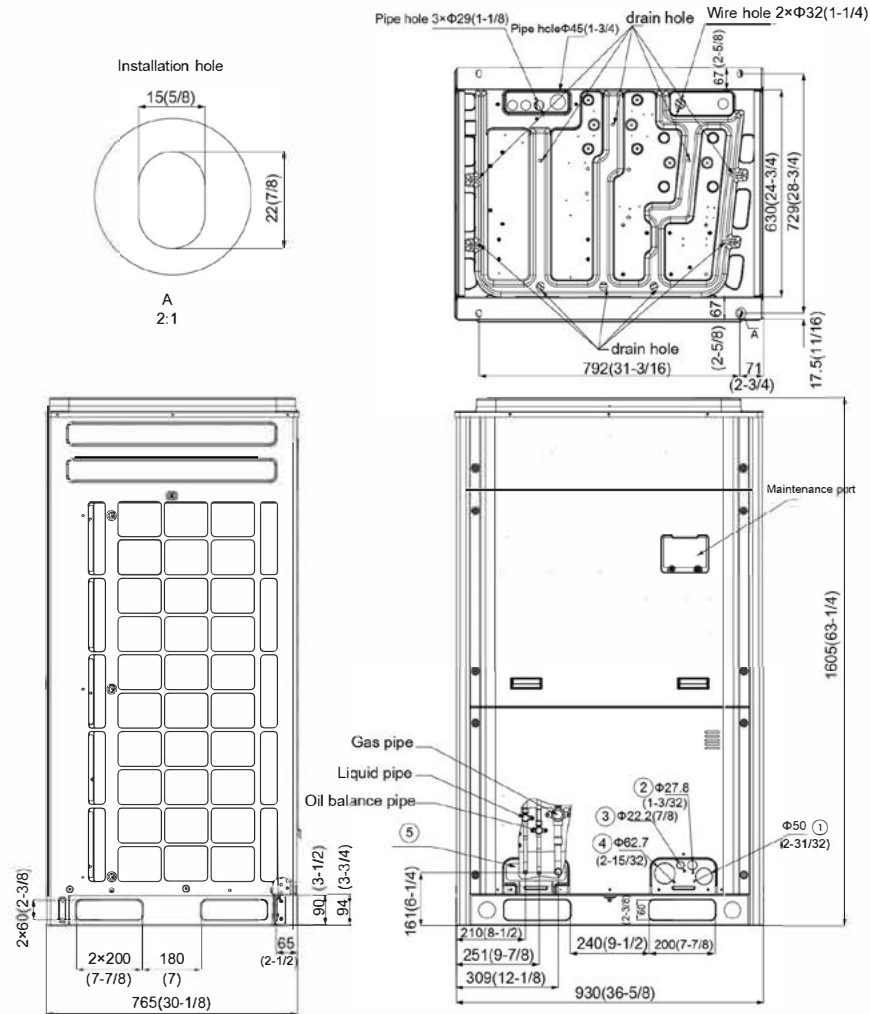

No.	Usage	Size mm(in.)
●	Wire	Φ50(2-31/32)
●		Φ27.8(1-3/32)
③		Φ22.2(7/8)
④		Φ62.7(2-15/32)
●	Pipe	180×53(7×2)

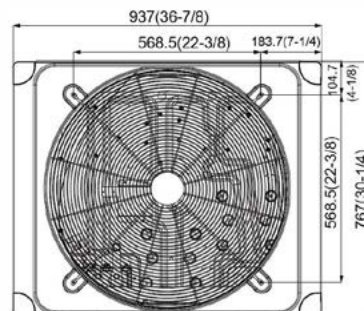

Unit:mm(in.)

NOTE: SEACOAST protection available upon request.

