

Modular Solar GMV 208~230V



Job Name: _____ Date: _____

System Reference No.: _____ Engineer Signature: _____

Model: GMV-Y96WM/C-F(U)



Specifications	Unit	Parameter
Performance		GMV-Y96WM/C-F(U)
Rated Cooling Capacity(*1)	kBtu/h	92
Rated Heating Capacity(*2)	kBtu/h	103
Power Input	Cooling(kw)	7.3
	Heating(kw)	7.85
Sound Pressure Level	dB(A)	61
Operating Temperature Range	Cooling(Outdoor) °C/°F	-5~52 / 23~125.6
	Heating(Outdoor) °C/°F	-20~24 / -4~75.2
AHRI Ratings (Ducted/Non-Ducted)		
EER		11.2
IEER		20 / 22
HSPF		2.25~3.3 / 2.3~3.5
Electrical Data		
Power supply	Voltage, Phase, Hertz	208/240, 3, 60
Maximum Overcurrent Protection (MOP)	A	45(208V) / 40(240V)
Minimum Circuit Amps (MCA)	A	43.6(208V) / 37.3(240V)
Solar DC Electrical Data		
Open Circuit Input Voltage Range	V	550~1000
Operating Voltage Input Range	V	500~780
Max. Solar Short Circuit Current	A	15
Fan		
Type x Quantity		Axial-flow x 2
Air Flow Volume	CFM	8240
External static Pressure	In. W.G	0.33
Compressor		
Compressor Type x Quantity		Inverter Scroll x 1
Compressor Refrigerant Oil type		FVC68D or FV-68H
Compressor Refrigerant Oil Charge Volume	L/Gal	5.1 / 1.35
Refrigerant Piping		
Connection Pipe	Gas (mm/inch)	7/8
	Liquid (mm/inch)	3/8
Max. Equivalent Connection Pipe Length (OD to ID)	ft	541
Refrigerant Charge	lbs	24.91
Refrigerant		R410A
Dimension/Weight		
Dimensions (HxWxD)	inch	63-1/4 x 52-3/4 x 30-1/8
Net Weight	lbs	650
Other		
Indoor Unit	Total Capacity(%)	50%-135% of outdoor unit
	Max Connectable Quantity	16
Safety Certification		ETL / AHRI / ENERGY STAR
Condenser Fin Color		Gold
Protection Devices	High Pressure	High pressure sensor, High pressure switch 601 psi (4.15 MPa)
	Inverter Circuit	Over-heat protection, Over-current protection
	Compressor	Discharge temp protection, Over-current protection

*1 Cooling | Indoor: 80°F(26.7°C)DB / 67°F(19°C)WB; Outdoor: 95°F(35°C)DB

*2 Heating | Indoor: 70°F(21.1°C)DB / Outdoor: 47°F(8.3°C)DB / 43°F(6°C)WB

Outline and Physical Dimensions of GMV-Y96WM/C-F(U).

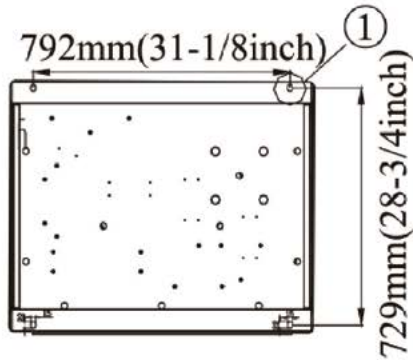

① Installation hole

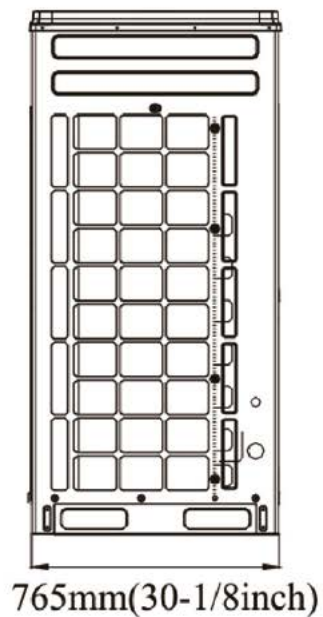
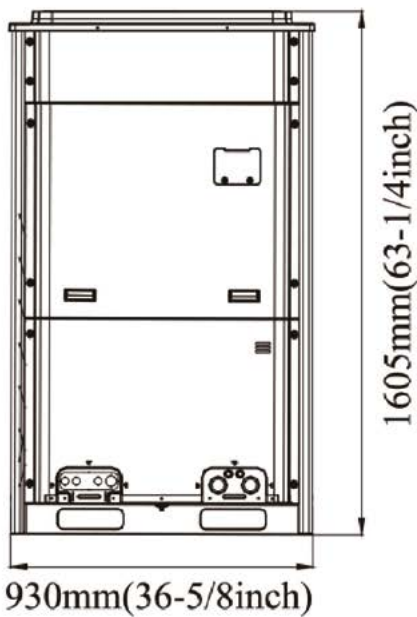
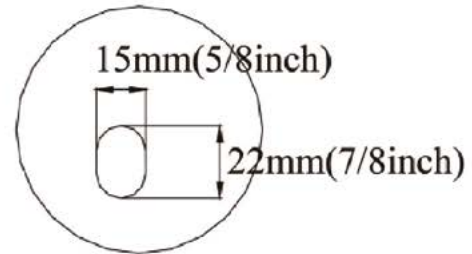

Unit:mm(in.)

NOTE: SEACOAST protection available upon request.

